

Modeling the Motion of a Spring

Consider a weight attached to a spring that is suspended from a horizontal bar as illustrated in the figure. When the object comes to rest we say it is at "equilibrium" which is labeled 0 on the vertical number line. If you give the weight a push, either up or down, it will start to move and the motion can be modeled by sine and cosine functions. The "stiffness" of the spring and the mass of the object affect how far the object moves from the equilibrium position. The initial velocity and initial position also affect the motion of the spring. (We don't always start at the equilibrium position.)

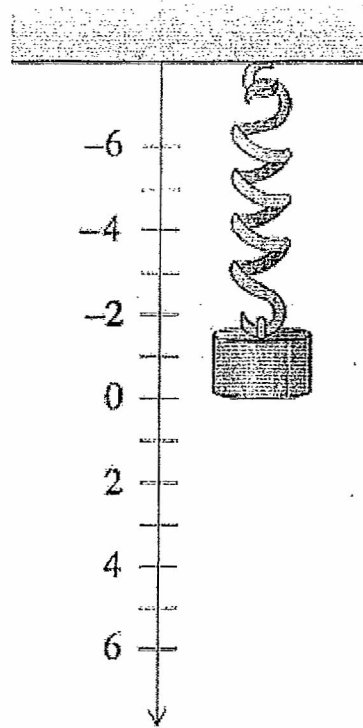

If we neglect any damping forces (air resistance etc.) then the motion of the spring can be modeled by

$$x(t) = \frac{v_0}{\omega} \sin(\omega t) + x_0 \cos(\omega t)$$

where $x(t)$ is the position of the object along the number line at time t . The other quantities are constants: ω is a constant that depends on the stiffness of the spring and the mass of the weight, v_0 is the initial velocity, and x_0 is the initial position of the object.

Model the motion of a weight on a spring:

Suppose a weight is set in motion from a position 3 centimeters below the equilibrium position and with a downward velocity of 4 centimeters per second. (Please note that the vertical number line used for position is "upside down". This is a convention from physics and it means that positions below equilibrium actually correspond to a positive value.) Assume that the spring stiffness and mass of the weight mean that $\omega = 2$ for this system.

Part I

1) Write the function $x(t)$ that gives the position of the weight as a function of time t in seconds. (Your function should consist of a sine term and a cosine term.)

$$x(t) = 2 \sin(2t) + 3 \cos(2t)$$

2) Graph the separate sine and cosine components of your function from (1) on the same set of axes. That is graph $x_1 = \frac{v_0}{\omega} \sin(\omega t)$ and $x_2 = x_0 \cos(\omega t)$ on the set of axes below.

(Sketch these graphs by hand and show two full cycles.)

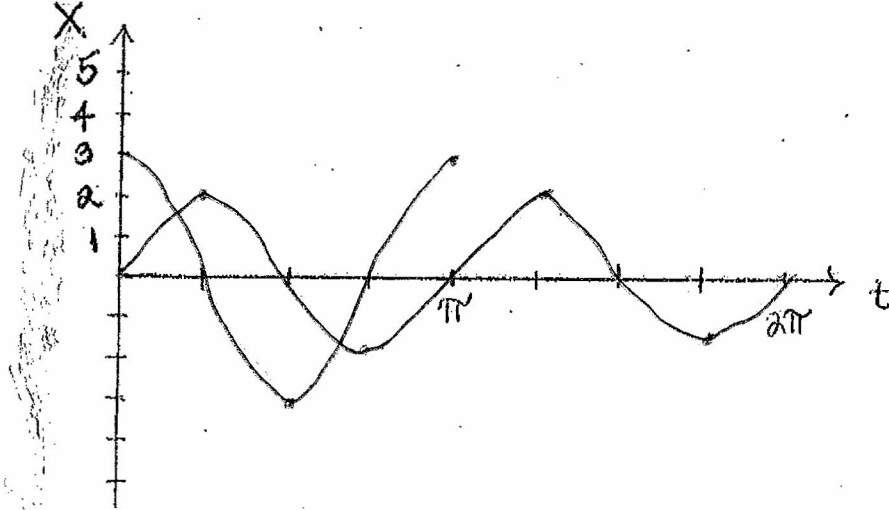

3) Use your calculator to graph the entire function from part (1). Use the window settings indicated below. Sketch what you see on your calculator display.

xmin = 0
 xmax = 2π
 xscl = $\frac{\pi}{4}$
 ymin = -5
 ymax = 5
 yscl = 1

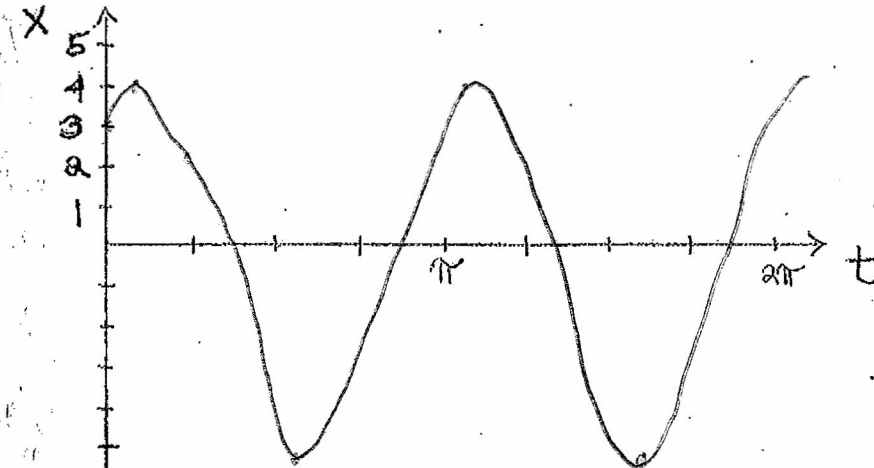

How are the graphs from part 2) related to the graph in part 3)? Please write a one or two sentence explanation.

The two graphs in problem 2 are combined in the graph in problem 3.

4) Write an equation for your calculator graph in the form $x(t) = A \cos[B(t-C)]$. (Use your trace or maximum feature to help you find values for A, B, and C. I expect to see decimal approximations for these values.)

$$3.6 \cos[2(t - .33)]$$

Part II:

5) Prove that the following is an identity (A is a positive constant):

$$\begin{aligned}
 A \sin \phi \sin(\omega t) + A \cos \phi \cos(\omega t) &= A \cos(\omega t - \phi) \\
 A \sin \phi \sin(\omega t) + A \cos \phi \cos(\omega t) &= A \cos(\omega t - \phi) \\
 &= A [\cos(\omega t) \cos \phi + \sin(\omega t) \sin \phi] \\
 &= A \cos \omega t \cos \phi + A \sin(\omega t) \sin \phi \\
 &= A \sin \phi \sin(\omega t) + A \cos \phi \cos(\omega t)
 \end{aligned}$$

Part III:

Rewrite an expression of the form $c_1 \sin(\omega t) + c_2 \cos(\omega t)$ in terms of a cosine function:

$A \cos(\omega t - \phi)$. Use the following definitions and your result from part II:

$$A = \sqrt{c_1^2 + c_2^2}$$

$$\left. \begin{aligned}
 A \sin \phi = c_1 &\Rightarrow \sin \phi = \frac{c_1}{A} \\
 A \cos \phi = c_2 &\Rightarrow \cos \phi = \frac{c_2}{A}
 \end{aligned} \right\} \tan \phi = \frac{c_1}{c_2}$$

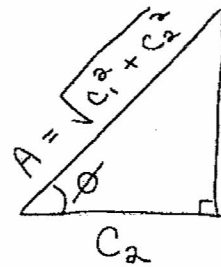

Visual Reminder

Please Note that c_1, c_2 may possibly be negative.

A , is the amplitude of the cosine function and ϕ , "phi", is called the phase angle and is measured in radians.

Example: Write $4 \sin 3t + 2 \cos 3t$ in terms of a cosine function.

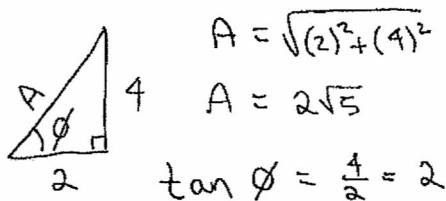

$$A = \sqrt{(2)^2 + (4)^2}$$

$$A = 2\sqrt{5}$$

$$\tan \phi = \frac{4}{2} = 2$$

$$\phi = \tan^{-1}(2) \approx 1.12$$

! Radian mode !

$$\begin{aligned}
 4 \sin 3t + 2 \cos 3t &\approx 2\sqrt{5} \cos(3t - 1.12) \\
 &\approx 2\sqrt{5} \cos[3(t - 0.37)]
 \end{aligned}$$

Because ϕ is approximate

6) Rewrite your function from (1) in terms of a cosine function: $A \cos(\omega t - \phi)$. Show your work.

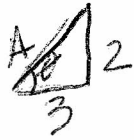

$$2 \sin(2t) + 3 \cos(2t) \approx \sqrt{13} \cos(2t - 0.59)$$

$$A = \sqrt{(1.3)^2 + (2)^2}$$

$$A = 13$$

$$\tan \theta = \frac{2}{3}$$

$$\theta = \tan^{-1}(2/3) \approx 0.59$$

7) Compare your function from (4) and (6). What do you observe? Write a one or two sentence explanation.

$$(4) 3.6 \cos [2(t - .33)] = 3.6 \cos(2t - .66)$$

$$(6) \sqrt{13} \cos(2t - 0.59) \approx 3.6 \cos(2t - .59)$$

The equations are almost identical. By looking at the curve you can approximate almost the exact equation.